

# ASSEMBLY D

# CLUTCH

## LIST OF CONTENTS

	Page
I - Brief specification of clutch .....	3
II - Clutch operation .....	3
III - Clutch dismounting from and mounting onto the vehicle .....	4
IV - Clutch disassembling, repair and reassembling	4
V - Clutch adjusting and readjusting .....	5
VI - Repair of clutch pressure plate .....	6
VII - Repair of flywheel .....	6
VIII - Adjustment of clutch clearance on the clutch release (declutching) bearing ..	7
IX - Replacement of clutch release bearing .....	8
X - Replacement of clutch control Bowden cable ..	8

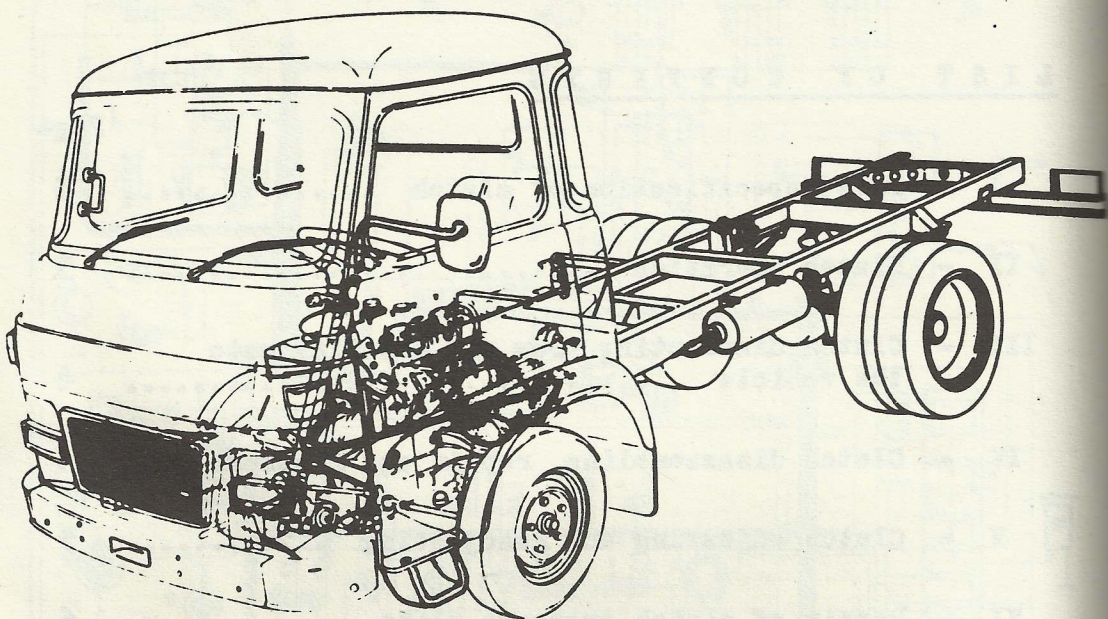

## I - BRIEF SPECIFICATION OF CLUTCH

Clutch model .....	10 LF 22 (stamped on the clutch housing cover);
Clutch design type .....	Dry, single-plate, axially spring-cushioned, provided with a clutch release thrust ball bearing and with an engagement damper;
Thickness of clutch lining .....	$8.7 \pm 0.3$ mm
Clutch clearance (checked at the clutch release thrust bearing) .....	3 mm
Number of clutch compression springs .	9 pcs.
- Diameter of spring wire .....	4 mm
- Operating force of of a clutch spring, when being compressed down to its height of 39.6 mm .....	615 N $\pm 8\%$ ;

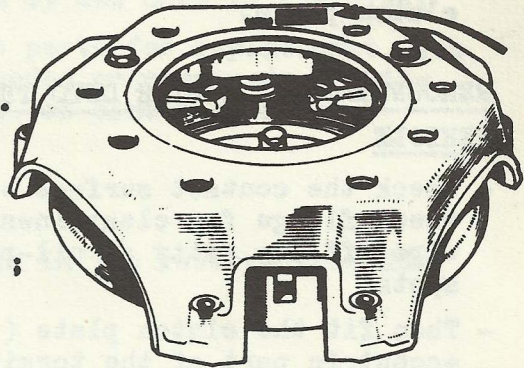

## II - CLUTCH OPERATION

The clutch pedal depressing is by means of the clutch control cable transmitted onto the clutch release fork 1 which actuates the clutch hub 2 c/w clutch release bearing as far as the bearing comes in contact with the clutch release levers 3. The clutch release bearing 2 displacement goes on and the clutch release levers 3, rotating around their journals, become depressed, by means of which the thrust resistance of pressure springs 6 gets overcome and thus becomes the clutch pressure plate 5 distant (pressed) from the clutch friction plate 7 (provided with clutch lining). At this moment becomes the clutch coupling of the engine and gearbox declutched (released).

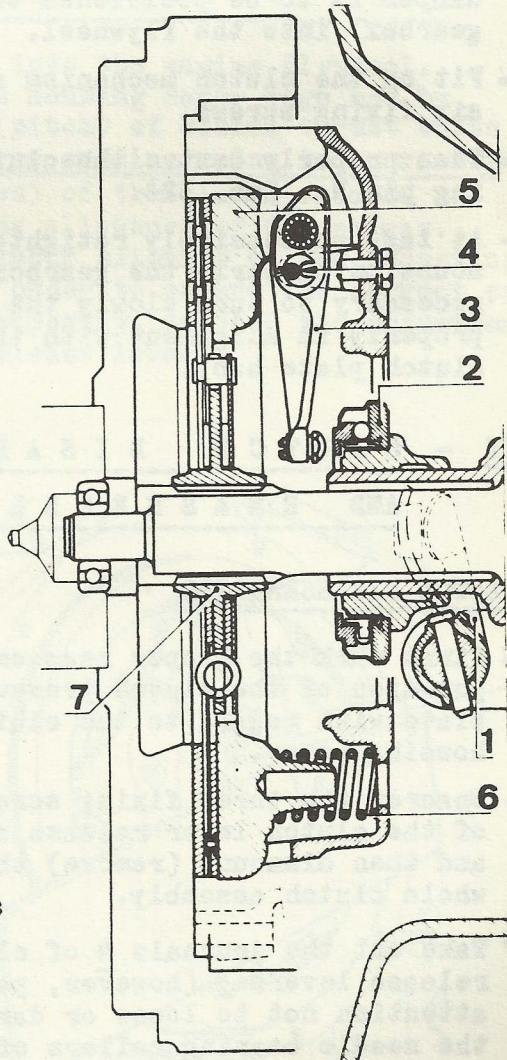

And on the contrary, as soon as the clutch pedal (foot pressure) becomes released, the clutch pressure plate 5 is now being pressed (by the pressure springs 6) to contact the clutch plate 7 again. Thus becomes renewed the coupling of fly-wheel with the power unit.

### III - CLUTCH DISMOUNTING FROM AND MOUNTING ON THE VEHICLE

#### CLUTCH REMOVING FROM THE VEHICLE

- First of all remove the gearbox from the vehicle.
- Then dismount the clutch mechanism from the vehicle and take out the clutch plate.

#### REMOVING THE CLUTCH ONTO THE VEHICLE

- Check the contact surface of Flywheel flange for cleanliness and wipe off any fatty or oil-polluted spots.
- Then fit the clutch plate (the eccentric part of the torsion damper is to be positioned to the gearbox) into the flywheel.
- Fit on the clutch mechanism and screw in, but not yet tighten, all six fixing screws.
- Then properly centre the clutch hub by means of the auxiliary centring pin No. Emb. 324.
- At last successively retighten and duly lock the fixing bolts and, mount on properly the gearbox (at this fitting-in operation it is necessary to turn slowly the gearbox input shaft and to adjust it properly in alignment with the splineways (inner grooves) of the clutch plate hub).

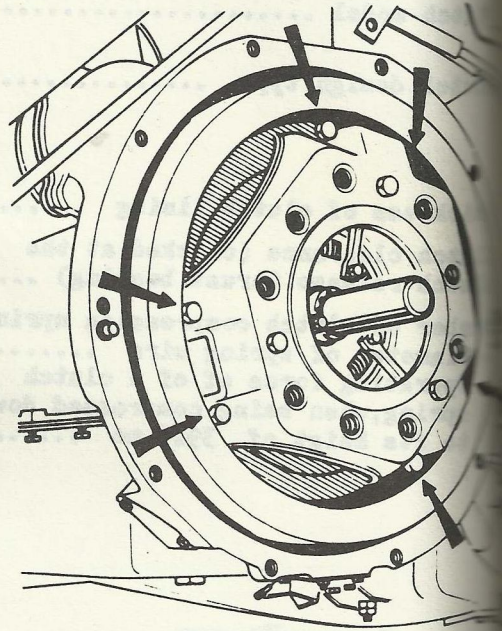

### IV - CLUTCH DISASSEMBLING, REPAIR AND REASSEMBLING

#### CLUTCH DISASSEMBLING

- First mark the proper reassembling position of the clutch pressure plate with regard to the clutch housing cover.
- Unscrew the three fixing screws of the clutch lever release forks and then dismount (remove) the whole clutch assembly.
- Take out the journals 4 of clutch release levers 3 (however, pay due attention not to loose or damage the needle bearing rollers of the clutch release levers - see the preceding two illustrations).

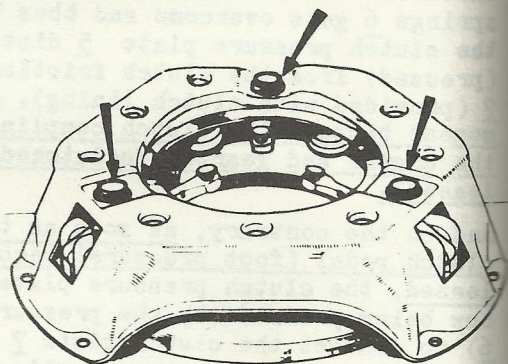

Carefully inspect and duly clean the separate parts of the clutch assembly and replace all defective or damaged parts by new ones.

If any of the clutch pressure springs (owing to a fatigue failure, stress or material defect) gets faulty, it is recommended to test the springing strength and further serviceability also of the other clutch pressure plate springs. The pressure strength of all clutch pressure springs has to be quite uniform and, therefore, springs of weak pressure strength are to be replaced by new ones in due time.

When ordering the clutch springs as spare parts for replacement, you are clearly to state in your order the needed or required quantity (number of pieces) and the proper Part No. of clutch springs.

### CLUTCH REASSEMBLY

to be carried out simply and successively in the reverse procedure than its disassembly.

### - CLUTCH ADJUSTING AND READJUSTING

Fit the clutch mechanism c/w clutch plate into the engine flywheel. Then apply an auxiliary rule to the clutch housing cover edge and by means of a depth gauge check the spacing (pitch) of clutch thrust bolts to the clutch housing cover edge. The true spacing value is correctly to be 23,5 - 1,5 mm. The flatness (evenness) of the clutch release contact surface is to be kept up within the allowance of 0,3 mm max. After having adjusted the spacing value, knock slightly on the adjusting screw heads by means of a light hammer in order to ensure the correct position of clutch release levers and, if necessary, recheck the adjustment and readjust the position of the clutch release levers.

After having finished the position adjustment, dismount the clutch mechanism from the engine flywheel again and lock the adjusting screws by anchoring the bevel parts of clutch release levers into the adjusting screw head slits.

**NOTE:** Never forget to add the thickness of the applied auxiliary rule when checking the spacing (distance) of the thrust bolt heads from the clutch housing bearing surface by means of a depth gauge (see the illustration on the side).

At the adjusting operation may the adjusting screws in some cases become damaged and, therefore, it is recommended to have available some spare adjusting screws for such a case.

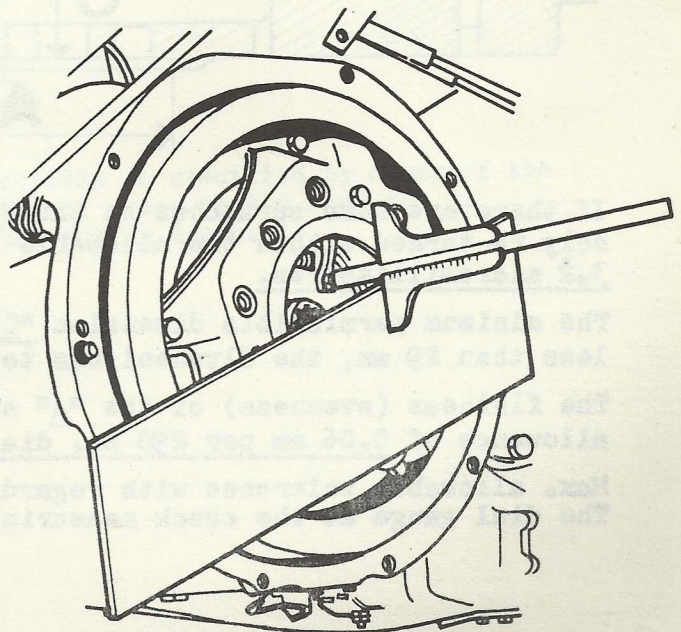

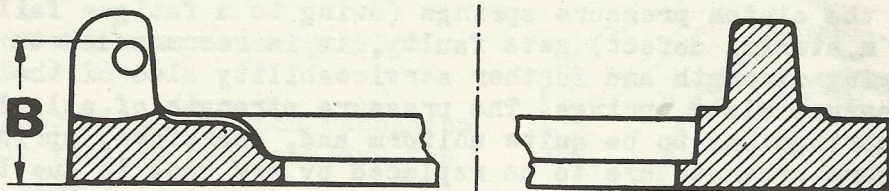
VI - REPAIR OF CLUTCH PRESSURE PLATE

If the contact surface of the clutch pressure plate becomes anyhow damaged (scratches, cracks, fissures or overtaper ratio), it has to be turned or reground. There-turning of clutch pressure plate surface must be very fine (turning fineness tolerance  $R_a = 1.6$  micromillimetre).

The flatness (evenness) of the clutch pressure plate contact surface is to be kept up at this regrinding or re-turning operation within the allowance range of up to 0.10 mm (max.).

Minimum permissible thickness of the clutch pressure plate after regrinding or re-turning it: dimension "B" = 36.4 mm. (see the illustration above).

If this allowable minimum dimension is not kept up at the reconditioning operation, the clutch pressure plate becomes unserviceable and is to be replaced by a new one.

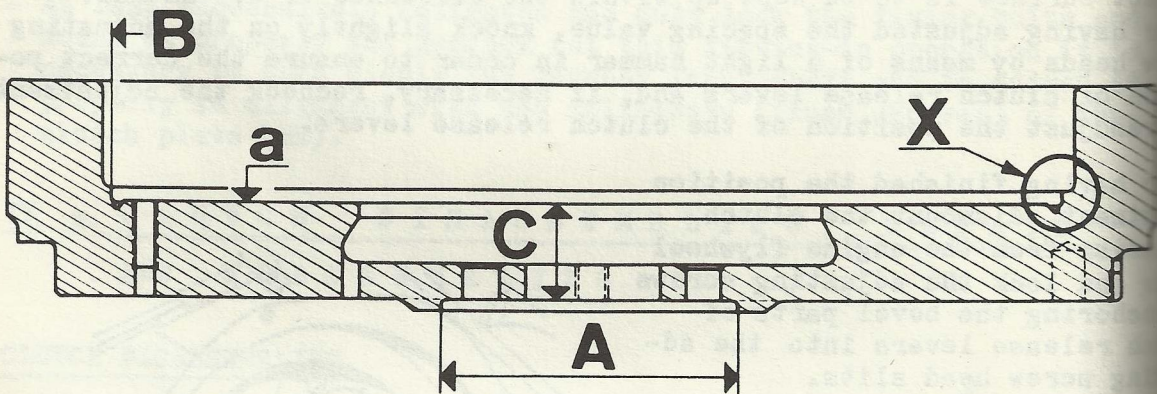
VII - REPAIR OF FLYWHEEL

If there are some scratches on the "a" bearing surface, it has to be newly re-turned within the allowable surface fineness range of  $R_a = 1.6$  3.2 micromillimetres.

The minimum permissible dimension "C" = 29 mm. If the dimension "C" is less than 29 mm, the flywheel has to be replaced by a new one.

The flatness (evenness) of the "a" surface is to be kept up within the allowance of 0.06 mm per 290 mm. dia.

Max. allowable tolerance with regard to the "A" dimension = 0.10 mm. The dial gauge at the check measuring is to be fixed to the surface.

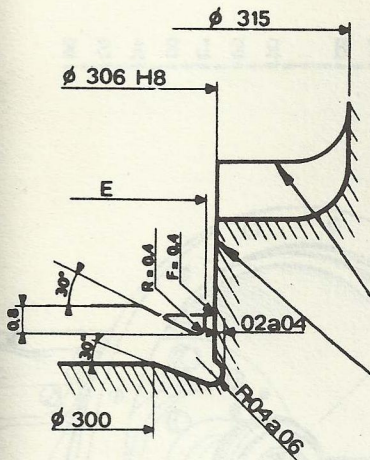

Instructional Illustration Here Aside:

A magnified graphic representation of the "X" detail for the sake of a precise professional machining of that part of flywheel, specified as "C" dimension in the preceding illustration.

(see the preceding Fig.)

Thin line = Working dimension;

Thick line = "X" detail of the flywheel after having finished its machining (fine grinding) - max. 2 mm;

VIII - ADJUSTMENT OF CLUTCH CLEARANCE ON THE CLUTCH RELEASE BEARING

- First release the return spring and loosen the lock nut 1.
- Displace the clutch release lever forwards as far as you start to feel a bearing resistance of the clutch release bearing while bearing against the bolt heads of the clutch release levers.
- Simultaneously pull the clutch control cable rearwards by hand and check the resulting spacing between the adjusting nut 2 and its bearing surface on the hexagonal stud of the clutch release lever (see the illustration here aside).

If the adjustment of the clutch control cable tension (by means of the adjusting nut 2) is correct, the above mentioned spacing (i.e. the clearance or dead travel of the clutch control release lever) should equal to 5 to 6 mm.

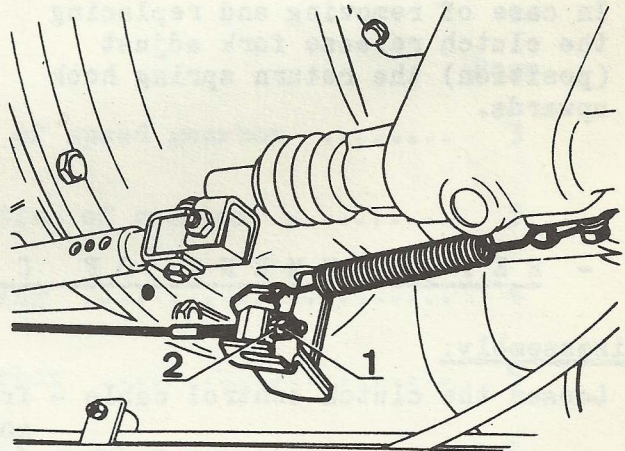

Otherwise readjust the spacing correctly as specified by means of the adjusting nut 2 and lock it properly by means of the lock nut 1. Then hook on the disconnected return spring again.

### IX - REPLACEMENT OF CLUTCH RELEASE BEARING

- First of all release the return spring 3.
- Then take out the clutch release bearing 1 completely with its hub 2.
- Press the hub 2 out of the clutch release bearing. Then press on the new clutch release bearing.
- Finally fit the clutch release bearing assembly on the guide and carrier tube at the front cover of gearbox and, at last fit on the return spring 3.

#### Note :

In case of removing and replacing the clutch release fork adjust (position) the return spring hook upwards.

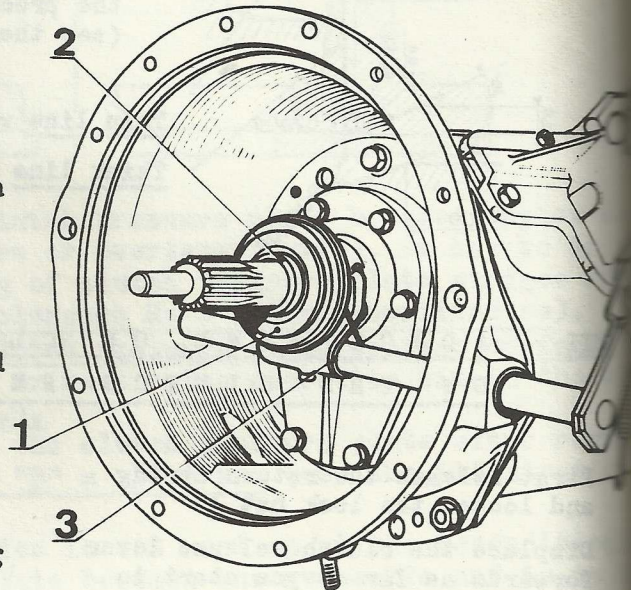

### X - REPLACEMENT OF CLUTCH CONTROL

#### Disassembly:

- Loosen the clutch control cable - from the clutch pedal lever - by removing the joint pin;
- from the clutch release fork - after removing the lock nut and the adjusting nut;
- release the ends of the bowden cable tubing from their supports, front and rear.
- Pull out the complete bowden cable tubing.

#### Reassembly:

Reverse the procedure of disassembly.

Adjust the clearance of the clutch release bearing (in accordance with chapter VIII).

Before refitting the cable, fill the bowden cable tubing and partly also the dustboots with grease.